

Vortex 110 Volt T1965

Tacx

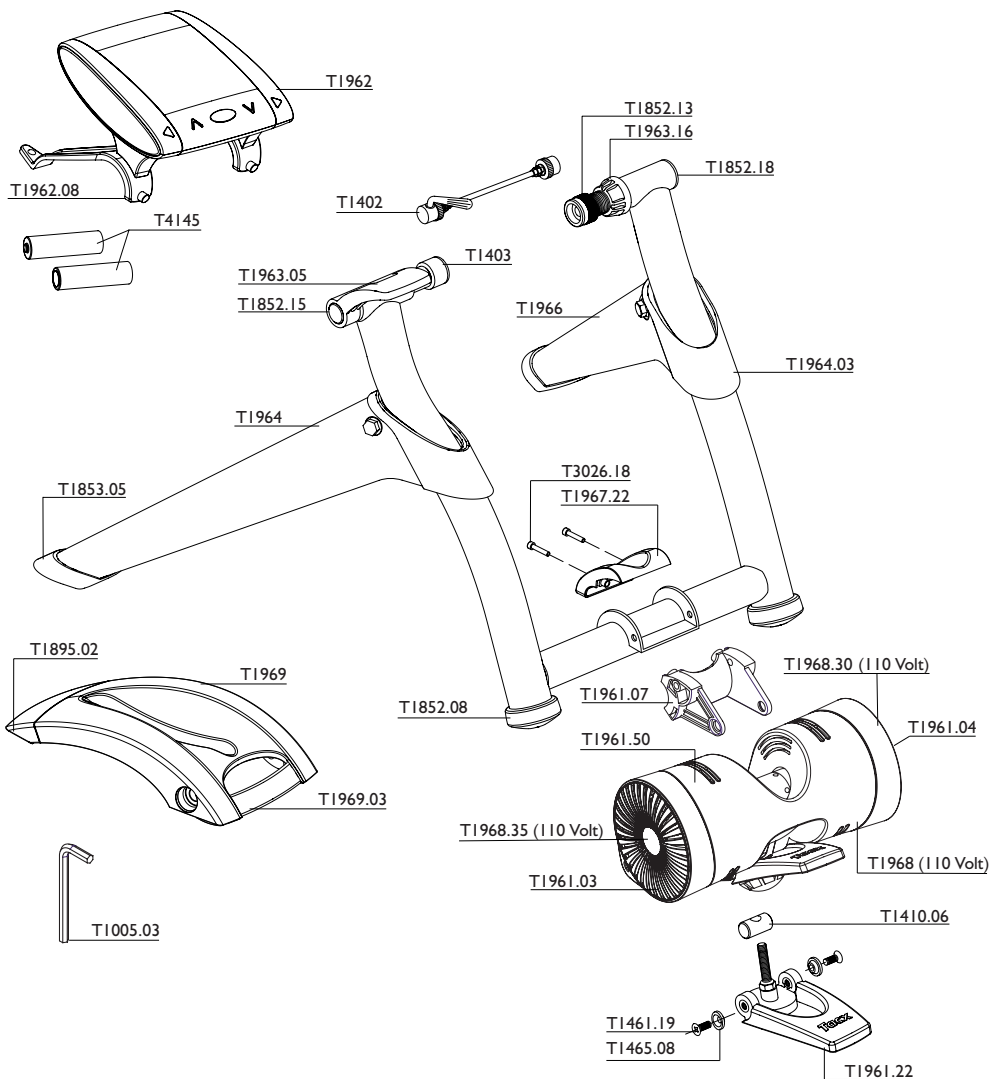
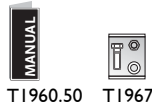

- T1005.03** Allen Key 5 mm
- T1402** Quick Release, rear wheel
- T1403** Quick release holder
- T1410.06** Spacer, M8
- T1461.19** Screw, M6 x 12
- T1465.08** Washer for hinge
- T1852.08** Rubber foot rear frame
- T1852.13** Bolt, M20 (with quick release)
- T1852.15** Slide part, round 20mm
- T1852.18** Screen capsule, M20
- T1853.05** Rubber foot frontleg
- T1895.02** Rubber frontfoot
- T1960.50** Vortex manual set
- T1961.03** Endcap Vortex brake
- T1961.04** Endcap Vortex brake for connector
- T1961.07** Position block Vortex
- T1961.22** Quick release lever Vortex
- T1961.50** Bearingblock Vortex complete
- T1962** Vortex computer
- T1962.08** Handlebar clamp Vortex computer
- T1963.05** Lever Vortex, green
- T1963.16** Star knob, M20 x 2, green
- T1964** Frontfoot complete, left
- T1964.03** Manchet frontleg Vortex
- T1966** Frontleg complete, right
- T1967** Fitting kit Vortex
- T1967.22** Clamp piece Vortex
- T1968** Vortex resistance unit 110 Volt
- T1968.30** Electro unit Vortex brake 110 Volt
- T1968.35** Spool unit Vortex brake 110 Volt
- T1969** Skyliner Vortex
- T1969.03** Handlebar Skyliner Vortex
- T3026.18** Bolt, M6 x 30
- T4145** Set of AA Batteries (4)